

FLEX-6000 SIGNATURE SERIES
FLEX-6000 HARDWARE REFERENCE MANUAL

Version ***1.6.21***

2/08/2016

VERSION HISTORY

Version #	Implemented By	Revision Date	Approved By	Approval Date	Reason
1.0.0	Greg Jurrens	9/30/2013	Lori Hicks	9/30/2013	Original Draft
1.0.1	Greg Jurrens	10/1/2013	Tim Ellison	10/1/2013	Minor Edits – Name change
1.0.5	Greg Jurrens	12/3/2013			Revised sec. 6.2 & 7.4 for clarity. Added sec. 11 (GPSDO)
1.1.3	Lori Hicks	2/17/2014	Greg Jurrens	2/18/2014	Moved to SVN Doc. Control Process. Added Voltage levels. Minor Edits
1.2.0	Matt Youngblood	5/8/2014			Added FLEX-6300
1.2.1	Tim Ellison	6/3/2014			Various formatting edits. Added 6300 specs
1.2.17	Matt Youngblood	7/1/2014			Updated Power Button Description
1.3.0	Tim Ellison	8/15/2014			Various minor edits and editions.
1.4.0	Tim Ellison	1/30/2014			Added section on FHM-1 Added ATU section Various minor edits
1.4.0	Lori Hicks / Ken Simmons	2/4/2015			Added information for the FLEX-6700R
1.4.0	Tim Ellison	3/16/2015			Miscellaneous minor edits. Added section on Calibration
1.4.11	Tim Ellison	5/11/2015			Miscellaneous minor edits and corrections
1.4.16	Tim Ellison	6/30/2015			Miscellaneous minor edits
1.5.0	Tim Ellison	9/14/2015			Miscellaneous edits and minor corrections
1.5.1	Tim Ellison	10/6/2015			Miscellaneous edits and minor corrections
1.6.17	Tim Ellison	1/11/2016			Miscellaneous edits and minor corrections
1.6.21	Tim Ellison	2/08/2016			Miscellaneous edits and minor corrections

TABLE OF CONTENTS

1	INTRODUCTION.....	7
1.1	Welcome	7
1.2	Manual Layout.....	7
1.3	Notices to the User.....	8
2	WARRANTY INFORMATION.....	9
3	IMPORTANT NOTICE – READ BEFORE OPERATING THIS UNIT	10
3.1	Precautions.....	10
3.2	Legal Notices	11
3.3	Copyright Information.....	13
4	SPECIFICATIONS.....	14
4.1	General.....	14
4.2	Transmitter	15
4.3	Receiver	15
5	UNPACKING AND INSPECTATION.....	16
5.1	Unboxing.....	16
5.2	Visual Inspection.....	16
5.2.1	General	16
5.2.2	Radio.....	16
5.2.3	Included Accessories.....	16
5.2.4	Additional Items not Included but Required	17
5.3	Reporting Damage	17
6	FRONT PANEL CONTROLS AND CONNECTIONS	18
6.1	Microphone Jack	19
6.1.1	Connector Pinout.....	19
6.1.2	Supported Microphone Types.....	19
6.2	Headphone Jack	19
6.3	CW Key/Paddle Jack	19
6.4	Multi-Function Display.....	20
6.5	Navigation Keys	20
6.6	Multi-Function Indicator LED.....	20
6.6.1	Chart for Indicator Color Codes	20
6.6.2	Chart for Indicator Color Codes with optional GPSDO Installed	20
6.7	Power Switch	21
6.7.1	“Soft Power Control” Multiple Operations	21

7 REAR PANEL CONNECTIONS	22
7.1 DC Power Input.....	23
7.1.1 Power Pole 30 Amp.....	24
7.1.2 Fused Internally at 30 Amps	24
7.2 USB 2.0 Ports.....	24
7.3 Powered Speakers	24
7.4 Accessory Connector	25
7.4.1 Pin 1: Line In	25
7.4.2 Pin 2: Line1 Out	25
7.4.3 Pin 3: Line2 Out	25
7.4.4 Pin 4: KEY/FSK/INT In	25
7.4.5 Pin 5, Reserved for future use (FLEX-6300 only).....	25
7.4.6 Pin 5, Pin 6, Pin 7, Pin 8 and Pin 10: GROUND.....	25
7.4.7 Pin 9: +5VDC	26
7.4.8 Pin 11: Accessory TX.....	26
7.4.9 Pin 12: SDA I/O.....	26
7.4.10 Pin 13: Accessory TX REQ.....	26
7.4.11 Pin 14: PTT in	26
7.4.12 Pin 15: SCL I/O.....	26
7.5 10Mhz Reference Clock Input.....	26
7.5.1 Radio Oscillator Startup.....	26
7.6 TX Relay Outputs [1,2,3]	27
7.7 Transceiver Antenna Ports [1,2]	27
7.8 10MHz Reference Output (w/GPSDO option).....	27
7.9 Ethernet Connector	28
7.10 Balanced Audio Input	28
7.10.1 Balanced Audio Input Connectors	28
7.10.2 MIC vs. LINE Use.....	29
7.10.3 Line Level.....	29
7.11 GPS Antenna Input (w/GPSDO option).....	29
7.12 Remote Power On Input.....	29
7.13 External Amplifier ALC Input	29
7.14 TX Request Input (interlock)	29
7.15 PTT Input.....	30
7.16 Transverter Port	30
7.17 RX ANT-A RF Input	30
7.18 RX ANT-A RF Output.....	30
7.19 RX ANT-B RF Input (FLEX-6700/6700R only).....	30

7.20	RX ANT-B RF Output (FLEX-6700/6700R only)	30
7.21	Chassis Ground	31
7.22	AC Power Input	31
7.23	Outputs [1, 2, 3]	31
7.24	No Connection (NC)	31
7.25	Digital Inputs [1, 2]	31
7.26	Antenna Inputs [1, 2]	31
7.27	Attention Label	31
8	INSTALLATION	32
8.1	Safety	32
8.2	Radio Placement	32
8.3	Environmental Considerations	32
8.4	Connecting to a PC	32
8.4.1	Ethernet Cabling Requirements	32
8.4.2	Direct PC Connection (Link-Local)	33
8.4.3	Connecting via a Local Network	33
8.4.4	Installing SmartSDR	34
9	FHM-1 MICROPHONE	35
9.1	Specifications	35
9.2	Tone Switch	35
9.3	Best Practices	35
10	TRANSVERTER SETUP	36
10.1	Transmit Power Considerations	37
10.2	RF Connections - Common IF	37
10.3	RF Connections - Split IF	37
10.4	PTT Connections	38
10.5	Sequencers	38
10.6	Multiple Transverters	38
11	DIGITAL MODE SETUP (SOUND CARD INTERFACE)	39
12	ANTENNA CONSIDERATIONS	40
12.1	Antenna Selection	41
13	ANTENNA TUNER UNIT (ATU)	42
13.1	Specifications	42
14	OPTIONAL GPS DISCIPLINED OSCILLATOR (GPSDO) SETUP	43
14.1	GPSDO Introduction	43
14.2	GPS Antenna Placement	43

14.3 GPSDO Lock Sequence and Status Indicators..... 44

15 CALIBRATION 45

15.1 Frequency Calibration 45

16 KEY CONTACTS..... 46

16.1 Headquarters / USA 46

16.2 Europe 46

17 REGULATORY REQUIREMENTS 47

17.1 European Conformity (CE) 47

1 INTRODUCTION

1.1 WELCOME

Thank you for purchasing the FLEX-6000 Signature Series software defined radio (SDR) from FlexRadio Systems. The FLEX-6000 is an example of cutting edge SDR technology using Digital Down Conversion (DDC) for exceptional performance and distortion free reception. Direct Digital Up Conversion (DUC) eliminates analog mixing and IF amplification to minimize spurious output and in-band intermodulation distortion to ensure ultra-clean RF transmission.

The FLEX-6000 along with its SmartSDR software “ecosystem” represents the ultimate operating experience for amateur radio operators.

1.2 MANUAL LAYOUT

The **FLEX-6000 Hardware Reference Manual** is designed as a guide for use while installing, configuring, and integrating your FLEX-6000 into your amateur station. This manual expands on the **FLEX-6000 Quick Start Guide** regarding connection details and hardware configuration including basic connectivity information for interfacing with the more common types of third-party hardware. It is designed for use in conjunction with the **SmartSDR Software User’s Guide**. References to the **FLEX-6000 Software User’s Guide** will be provided to assist you.

Throughout this manual, important references will be highlighted for your information and safety. The following symbols and styles will be used:

! – WARNING: THIS MEANS THAT THERE IS A POTENTIAL SAFETY HAZARD IF THE RADIO IS CONFIGURED OR OPERATED IMPROPERLY. PAY SPECIAL ATTENTION TO ALL “!” WARNINGS.

Δ – CAUTION: This is a precautionary statement to acknowledge there is a risk to damaging your radio or operating it in an unintended manner. Pay special attention to the “Δ” symbol to get the most from your FLEX-6000.

I – Information: Important information will be highlighted with the “i” symbol. Read these notes for helpful hints and details about your FLEX-6000.

1.3 NOTICES TO THE USER

IMPORTANT NOTICE - READ BEFORE OPERATING THIS UNIT

WARNING!

This radio has been configured to operate in your country according to your nation's regulations. It will operate on frequencies which are not allowed for public use. You are required to have a valid amateur radio license of an appropriate class from your government to have the privileges to operate on amateur radio frequencies.

Except those actions which have been described in the **FLEX-6000 Quick Start Guide**, **FLEX-6000 Hardware Reference Manual**, and **SmartSDR Software User's Guide**, no other manipulations to the radio are allowed. The unit must only be opened and/or serviced by a qualified technician. Unauthorized repairs may damage the radio and void the manufacturer's warranty.

Please study the **FLEX-6000 Quick Start Guide** and the **FLEX-6000 Hardware Reference Manual** and **SmartSDR Software User's Guide** prior to operating the unit. These documents contain important information for safe operation.

For any questions due to misunderstanding, translation errors and alike, please refer to the **FLEX-6000 Hardware Reference Manual** and **SmartSDR Software User's Guide** first.

Radio frequency energy (RF) from transmitters can interact with some electronic devices, such as cardiac pacemakers and defibrillators. Please refer to the implanted pacemaker or defibrillator manufacturer's instructions with respect to precautions to be taken in the vicinity of an amateur radio transmitter. If any interaction or interference with a pacemaker or implanted defibrillator is suspected, STOP transmitting immediately.

2 WARRANTY INFORMATION

This Limited Hardware Warranty is effective as of the date of first shipment to the consumer. Original equipment warranties and manufacturer hardware support for the FLEX-6300, FLEX-6500 and FLEX-6700 applies only to the original purchaser and are not transferable unless a warranty transfer agreement is purchased from FlexRadio Systems. FlexRadio Systems may elect to transfer the hardware warranty to a third-party if the identity of the third-party is made known at the time of purchase. A Return Merchandise Authorization (RMA) number is required before sending in a product for service. An RMA number may be issued by FlexRadio Systems by submitting a HelpDesk support ticket and undergoing troubleshooting procedures with a technical support engineer. Any product returned for service that is out of warranty or has had its warranty voided is subject to a one (1) hour diagnostic bench charge (currently \$85 USD). This charge will be applied to any work performed.

What is covered: During the first two (2) years after date of purchase, FlexRadio Systems will replace defective parts free of charge (post-paid) for transceiver components only. Any replacement hardware parts will be warranted for the remainder of the original warranty period or ninety (90) calendar days from the date of installation or repair, whichever is longer. FlexRadio Systems will also correct any failure caused by defective parts and materials. The complete unit must be sent to FlexRadio Systems at your expense in the original shipping container or other packaging sufficient to prevent damage in transit. FlexRadio Systems is not responsible for damage or lost shipments from the customer. FlexRadio Systems will insure the package and pay return shipping.

What is not covered: This Limited Hardware Warranty as it pertains to the transceiver or radio components does not cover repair or damage caused by (1) misuse, negligence or user modifications; (2) any performance malfunctions involving non-FlexRadio accessory equipment; (3) connection to improper or unstable voltage supply; (4) the incorrect installation of any and all cables connected to the radio by the user; (5) the use of third-party software applications or hardware that directly or indirectly controls radio functions and/or operating state by utilizing a communication or control protocol, such as, but not limited to CAT or I2C commands, or (6) random acts of nature such as flood, fire, water, weather related storm, lightning or electrostatic discharge damage.

Limitation of Incidental or Consequential Damages: This warranty does not extend to non-FlexRadio equipment or components used in conjunction with our products. Any such repair or replacement is the responsibility of the customer. FlexRadio Systems will not be liable or responsible for reimbursement for any special, indirect, incidental or consequential damages, including but not limited to any loss of business or profits, loss of property, loss of revenue, loss of use, loss of data, inconvenience or cost of unauthorized service.

3 IMPORTANT NOTICE – READ BEFORE OPERATING THIS UNIT

3.1 PRECAUTIONS

! – THIS UNIT IS NOT A TOY. IT MUST NOT BE HANDLED BY CHILDREN NOR PLACED/OPERATED WITHIN REACH OF CHILDREN.

! – DO NOT LEAVE PACKING MATERIAL FOR THIS UNIT UNATTENDED. IT MAY BE HARMFUL TO CHILDREN IF MISUSED.

! – THIS UNIT CONTAINS SMALL PARTS THAT COULD BE A CHOKING HAZARD TO SMALL CHILDREN. DO NOT LEAVE ACCESSORIES UNATTENDED.

! – DO NOT OPERATE THIS UNIT IN POTENTIALLY EXPLOSIVE ENVIRONMENTS.

! – NEVER ATTEMPT TO INSERT WIRES OR ANY TOOLS INTO THE INTERIOR OF THIS UNIT DURING OPERATION. THIS MAY CAUSE FIRE OR ELECTRIC SHOCK.

! – THIS UNIT MUST ONLY BE OPERATED WITH THE ELECTRICAL POWER DESCRIBED IN THE FLEX-6000 QUICK START GUIDE. NEVER CONNECT THE +13.8VDC POWER CONNECTOR DIRECTLY TO AN AC OUTLET. THIS MAY CAUSE A FIRE, INJURY, OR ELECTRICAL SHOCK.

! – THE FLEX-6700R INCORPORATES DOUBLE POLE / NEUTRAL FUSING

! – NEVER CONNECT OR DISCONNECT ANTENNAS WHILE IN TRANSMIT MODE. THIS MAY CAUSE ELECTRICAL SHOCK OR RF BURNS TO YOUR SKIN AND DAMAGE TO THE UNIT.

! – THIS UNIT GENERATES RADIO FREQUENCY (RF) ENERGY. USE CAUTION AND OBSERVE PROPER SAFETY PRACTICES REGARDING YOUR SYSTEM CONFIGURATION. WHEN ATTACHED TO AN ANTENNA, THIS RADIO IS CAPABLE OF GENERATING RF ELECTROMAGNETIC FIELDS WHICH REQUIRE EVALUATION ACCORDING TO YOUR NATIONAL LAW TO PROVIDE ANY NECESSARY ISOLATION OR PROTECTION REQUIRED, WITH RESPECT TO HUMAN EXPOSURE!

Δ - This unit must only be opened and/or serviced by a qualified technician. Opening the unit may void the manufacturer's warranty

Δ - Do not operate this unit in areas of extreme humidity.

Δ - Avoid operating this radio in direct sunlight or other areas of extreme heat, excessive vibration, or mechanical force.

Δ - When using earphones, use caution when adjusting the volume to prevent any harm to your hearing.

Δ - If this unit is intended for use in commercial applications, special safety regulations and cautions may apply to prevent accidents.

Δ - If any defect, abnormal result, or other observations occur that are not covered by the Quick Start Guide; immediately cease operation and contact the manufacturer or local distributor for operational advice or repair of the unit.

I- No other physical modification of this radio is allowed. Any other use or modification (including software changes that affect operational characteristics) will void the manufacturer's warranty.

I- Ensure proper ventilation around the radio; this includes 2" clearance on the sides and back.

I- If you operate this unit in conjunction with a linear amplifier, always make sure your output power is below the maximum input limits of the amplifier. Consult your amplifier owner's manual for proper connection and operation.

3.2 LEGAL NOTICES

©2013-2015 FlexRadio Systems. All rights reserved. FlexRadio Systems®, SmartSDR™, and related trademarks, names, and logos are the property of FlexRadio Systems and are registered and/or used in the U.S. and countries around the world.

All other trademarks are the property of their respective owners.

This documentation including all documentation incorporated by reference herein such as documentation provided or made available at support.flexradio.com/downloads is provided or made accessible "AS IS" and "AS AVAILABLE" and without condition, endorsement, guarantee, representation, or warranty of any kind by FlexRadio Systems and FlexRadio assumes no responsibility for any typographical, technical, or other inaccuracies, errors, or omissions in this documentation. In order to protect FlexRadio proprietary and confidential information and/or trade secrets, this documentation may describe some aspects of FlexRadio technology in generalized terms. FlexRadio reserves the right to periodically change information that is contained in this documentation; however, FlexRadio makes no commitment to provide any such changes, updates, enhancements, or other additions to this documentation to you in a timely manner or at all.

This documentation might contain references to third-party sources of information, hardware or software, products or services including components and content such as content protected by copyright and/or third-party web sites (collectively the "Third Party Products and Services"). FlexRadio does not control, and is not responsible for, any Third Party Products and Services including, without limitation the content, accuracy, copyright compliance, compatibility, performance, trustworthiness, legality, decency, links, or any other aspect of Third Party Products and Services. The inclusion of a reference to Third Party Products and Services in this documentation does not imply endorsement by FlexRadio Systems of the Third Party Products and Services or the third party in any way.

EXCEPT TO THE EXTENT SPECIFICALLY PROHIBITED BY APPLICABLE LAW IN YOUR JURISDICTION, ALL CONDITIONS, ENDORSEMENTS, GUARANTEES, REPRESENTATIONS, OR WARRANTIES OF ANY KIND, EXPRESS OR IMPLIED, INCLUDING WITHOUT LIMITATION, ANY CONDITIONS, ENDORSEMENTS, GUARANTEES, REPRESENTATIONS OR WARRANTIES OF DURABILITY, FITNESS FOR A PARTICULAR PURPOSE OR USE, MERCHANTABILITY, MERCHANTABLE QUALITY, NON-INFRINGEMENT, SATISFACTORY QUALITY, OR TITLE, OR ARISING FROM A STATUTE OR CUSTOM OR A COURSE OF DEALING OR USAGE OF TRADE,

OR RELATED TO THE DOCUMENTATION OR ITS USE, OR PERFORMANCE OR NON-PERFORMANCE OF ANY SOFTWARE, HARDWARE, SERVICE, OR ANY THIRD PARTY PRODUCTS AND SERVICES REFERENCED HEREIN, ARE HEREBY EXCLUDED. YOU MAY ALSO HAVE OTHER RIGHTS THAT VARY BY STATE OR PROVINCE. SOME JURISDICTIONS MAY NOT ALLOW THE EXCLUSION OR LIMITATION OF IMPLIED WARRANTIES AND CONDITIONS. TO THE EXTENT PERMITTED BY LAW, ANY IMPLIED WARRANTIES OR CONDITIONS RELATING TO THE DOCUMENTATION TO THE EXTENT THEY CANNOT BE EXCLUDED AS SET OUT ABOVE, BUT CAN BE LIMITED, ARE HEREBY LIMITED TO NINETY (90) DAYS FROM THE DATE YOU FIRST ACQUIRED THE DOCUMENTATION OR THE ITEM THAT IS THE SUBJECT OF THE CLAIM.

TO THE MAXIMUM EXTENT PERMITTED BY APPLICABLE LAW IN YOUR JURISDICTION, IN NO EVENT SHALL FLEXRADIO SYSTEMS BE LIABLE FOR ANY TYPE OF DAMAGES RELATED TO THIS DOCUMENTATION OR ITS USE, OR PERFORMANCE OR NON-PERFORMANCE OF ANY SOFTWARE, HARDWARE, SERVICE, OR ANY THIRD PARTY PRODUCTS AND SERVICES REFERENCED HEREIN INCLUDING WITHOUT LIMITATION ANY OF THE FOLLOWING DAMAGES: DIRECT, CONSEQUENTIAL, EXEMPLARY, INCIDENTAL, INDIRECT, SPECIAL, PUNITIVE, OR AGGRAVATED DAMAGES, DAMAGES FOR LOSS OF PROFITS OR REVENUES, FAILURE TO REALIZE ANY EXPECTED SAVINGS, BUSINESS INTERRUPTION, LOSS OF BUSINESS INFORMATION, LOSS OF BUSINESS OPPORTUNITY, OR CORRUPTION OR LOSS OF DATA, FAILURES TO TRANSMIT OR RECEIVE ANY DATA, PROBLEMS ASSOCIATED WITH ANY APPLICATIONS USED IN CONJUNCTION WITH FLEXRADIO SYSTEMS PRODUCTS OR SERVICES, DOWNTIME COSTS, LOSS OF THE USE OF FLEXRADIO PRODUCTS OR SERVICES OR ANY PORTION THEREOF OR OF ANY COST OF SUBSTITUTE GOODS, COSTS OF COVER, FACILITIES OR SERVICES, COST OF CAPITAL, OR OTHER SIMILAR PECUNIARY LOSSES, WHETHER OR NOT SUCH DAMAGES WERE FORESEEN OR UNFORESEEN, AND EVEN IF FLEXRADIO HAS BEEN ADVISED OF THE POSSIBILITY OF SUCH DAMAGES.

TO THE MAXIMUM EXTENT PERMITTED BY APPLICABLE LAW IN YOUR JURISDICTION, FLEXRADIO SYSTEMS SHALL HAVE NO OTHER OBLIGATION, DUTY, OR LIABILITY WHATSOEVER IN CONTRACT, TORT, OR OTHERWISE TO YOU INCLUDING ANY LIABILITY FOR NEGLIGENCE OR STRICT LIABILITY.

THE LIMITATIONS, EXCLUSIONS, AND DISCLAIMERS HEREIN SHALL APPLY: (A) IRRESPECTIVE OF THE NATURE OF THE CAUSE OF ACTION, DEMAND, OR ACTION BY YOU INCLUDING BUT NOT LIMITED TO BREACH OF CONTRACT, NEGLIGENCE, TORT, STRICT LIABILITY OR ANY OTHER LEGAL THEORY AND SHALL SURVIVE A FUNDAMENTAL BREACH OR BREACHES OR THE FAILURE OF THE ESSENTIAL PURPOSE OF THIS AGREEMENT OR OF ANY REMEDY CONTAINED HEREIN; AND (B) TO FLEXRAIO AND ITS AFFILIATED COMPANIES, THEIR SUCCESSORS, ASSIGNS, AGENTS, AUTHORIZED FLEXRADIO DISTRIBUTORS AND THEIR RESPECTIVE DIRECTORS, EMPLOYEES, AND INDEPENDENT CONTRACTORS.

IN ADDITION TO THE LIMITATIONS AND EXCLUSIONS SET OUT ABOVE, IN NO EVENT SHALL ANY DIRECTOR, EMPLOYEE, AGENT, DISTRIBUTOR, SUPPLIER, INDEPENDENT CONTRACTOR OF FLEXRADIO SYSTEMS OR ANY AFFILIATES OF FLEXRADIOI HAVE ANY LIABILITY ARISING FROM OR RELATED TO THE DOCUMENTATION.

Prior to subscribing for, installing, or using any Third Party Products and Services, it is your responsibility to ensure that the supplier has agreed to support all of their features. Installation or use of Third Party Products and Services with FlexRadio System's products and services may require one or more patent, trademark, copyright, or other licenses in order to avoid infringement or violation of third party rights. You are solely responsible for determining whether to use Third Party Products and Services and if any third party licenses are required to do so. If required you are responsible for acquiring them. You should not install or use Third Party Products and Services until all necessary licenses have been acquired. Any Third Party Products and Services that are provided with FlexRadio's products and services are provided as a convenience to you and are provided "AS IS" with no express or implied conditions, endorsements, guarantees, representations, or warranties of any kind by FlexRadio and FlexRadio assumes no liability whatsoever, in relation thereto. Your use of Third Party Products and Services shall be governed by and subject to you agreeing to the terms of separate licenses and other agreements applicable thereto with third parties, except to the extent expressly covered by a license or other agreement with FlexRadio Systems.

The terms of use of any FlexRadio product or service are set out in a separate license or other agreement with FlexRadio applicable thereto. **NOTHING IN THIS DOCUMENTATION IS INTENDED TO SUPERSEDE ANY EXPRESS WRITTEN AGREEMENTS OR WARRANTIES PROVIDED BY FLEXRADIO SYSTEMS FOR PORTIONS OF ANY FLEXRADIO PRODUCT OR SERVICE OTHER THAN THIS DOCUMENTATION.**

3.3 COPYRIGHT INFORMATION

Copyright © 2013-2015 FlexRadio Systems
All rights reserved

Information in this document is subject to change without notice and does not represent a commitment on the behalf of FlexRadio Systems. No part of this publication may be reproduced, stored in a retrieval system, or transmitted in any form or by any means, electronic, mechanical, photocopying, recording or otherwise, for any purpose other than the purchaser's personal use, without the prior express written permission of FlexRadio Systems.

4 SPECIFICATIONS

4.1 GENERAL

Specification	FLEX-6300	FLEX-6500	FLEX-6700/R
Frequency Range (Transmitter) Note: not applicable to the FLEX-6700R			
<ul style="list-style-type: none"> Rated Output Power @ 100W nominal 	160m - 6m (Amateur bands only by country)	160m - 6m (Amateur bands only by country) + MARS	160m - 6m (Amateur bands only by country) + MARS
<ul style="list-style-type: none"> Transverter (XVTR) IF Output Port 	100 KHz - 54 MHz	100 KHz - 77 MHz	100 KHz - 77 MHz 135 - 165 MHz
Frequency Range (Receiver)			
<ul style="list-style-type: none"> Low Band (First Nyquist Zone) 	30 kHz – 54 MHz	30 KHz to 77 MHz	30 KHz - 77 MHz
<ul style="list-style-type: none"> High Band (Second Nyquist Zone) 	NA	NA	135 - 175 MHz
Emission Modes*	A1A (CW), A3E(AM), J3E (SSB) , F3E (FM)	A1A (CW), A3E(AM), J3E (SSB), F3E (FM)	A1A (CW), A3E(AM), J3E (SSB) , F3E (FM)
Frequency Stability			
<ul style="list-style-type: none"> Standard 	0.5ppm TCXO	0.5 ppm TCXO	0.02 ppm OCXO (60 sec @ 25C)
<ul style="list-style-type: none"> With GPSDO Option (GPS Locked) 	NA	5x10 ⁻¹² over 24 Hours	5x10 ⁻¹² over 24 Hours
Antenna Impedance - Unbalanced	50 Ohms	50 Ohms	50 Ohms
Antenna Tuner Load Range - Unbalanced	8.3 - 300 Ohms (80m – 10m) 6.7 - 150 Ohms (160m and 6m)	8.3 - 300 Ohms (80m – 10m) 6.7 - 150 Ohms (160m and 6m)	8.3 - 300 Ohms (80m – 10m) 6.7 - 150 Ohms (160m and 6m)
Standard Supply Voltage	+13.8 VDC +/- 15%	+13.8 VDC +/- 15%	+13.8 VDC +/- 15% (FLEX-6700) 100-240 VAC, 50-60 Hz (FLEX-6700R)
Supply Current (Receive/Transmit)	1.7A Receive Typ., 23A Transmit Max.	2A Receive Typ., 23A Transmit Max.	2A Receive Typ., 23A Transmit Max. % (FLEX-6700) 5W Standby/50W operating (FLEX-6700R)
Operating Temperature Range	0 to +50C, +32 to +122F	0 to +50C, +32 to +122F	0 to +50C, +32 to +122F
Dimensions			
<ul style="list-style-type: none"> With Feet 	13"W x 11.75"D x 3.875"H, 33cm x 29.8cm x 7.1cm	13"W x 12"D x 4"H, 33cm x 30.5cm x 10.2cm	13"W x 12"D x 4"H, 33cm x 30.5cm x 10.2cm
<ul style="list-style-type: none"> Without Feet (2U Rack Height) 	NA	13"W x 12"D x 3.5"H, 33cm x 30.5cm x 8.9 cm	13"W x 12"D x 3.5"H, 33cm x 30.5cm x 8.9 cm
<ul style="list-style-type: none"> Weight 	10 lbs., 4.5 kgs	13 lbs., 5.9 kgs	13 lbs., 5.9 kgs 10 lbs., 4.53 kgs (FLEX-6700R)

* - Other modes may be available through the addition of third-party waveform plug-ins.

4.2 TRANSMITTER

Specification	FLEX-6300	FLEX-6500	FLEX-6700 only
Transmitter Architecture	Direct Digital Up Conversion	Direct Digital Up Conversion	Direct Digital Up Conversion
TX DAC Resolution	16-bit	16-bit	16-bit
TX DAC Sampling Rate	122.88 Msps	491.52 Msps	491.52 Msps
Output Power CW/SSB/FSK/FM (AM) at 13.8 VDC (nominal)	100W (25W)	100W (25W)	100W (25W)
XVTR Port Power Output	0 dBm Typ., +15 dBm Max.	0 dBm Typ., +15 dBm Max.	0 dBm Typ., +15 dBm Max.
Modulation	DSP Generation	DSP Generation	DSP Generation
Spurious Emissions	HF: -50 dBc, 6m: -70 dBc 6m	HF: -60 dBc, 6m: -70 dBc 6m	HF: -60 dBc, 6m: -70 dBc 6m
Carrier Suppression	-80 dBc below peak output	-80 dBc below peak output	-80 dBc below peak output
Unwanted Sideband Suppression	-80 dBc below peak output	-80 dBc below peak output	-80 dBc below peak output
Transmit Frequency Response	Default 100-2900 Hz (Variable 50-10 kHz)	Default 100-2900 Hz (Variable 50-10 kHz)	Default 100-2900 Hz (Variable 50-10 kHz)
Microphone Impedance	600 Ohms Nominal, 200-10k Ohm	600 Ohms Nominal, 200-10k Ohm	600 Ohms Nominal, 200-10k Ohm

4.3 RECEIVER

Specification	FLEX-6300	FLEX-6500	FLEX-6700/R
Receiver Architecture	Direct Down Conversion	Direct Down Conversion	Direct Down Conversion
Spectral Capture Units	1	1	2
Maximum Slice Receivers	2	4	8
Maximum Spectral Displays (Panadapters)	2	4	8
ADC Resolution	16-bit	16-bit	16-bit
ADC Sampling Rate	122.88 Msps	245.76 Msps	245.76 Msps
Sensitivity (Typical MDS in 500 Hz BW, Preselector OFF) Preamp Off/10dB/20dB/30dB	-121 dBm/-125 dBm/-136 dBm/NA	-121 dBm/-125 dBm/-136 dBm/NA	-121 dBm/-125 dBm/-136 dBm/-141 dBm
Amateur Band Preselector Coverage	NA	160 - 6m (Except 60m)	160 - 6m (Except 60m), 2m
Image Rejection Ratio	>80 dB	>100 dB	>100 dB
External Powered Speaker Output Impedance/Level	10 kOhm / 2.6Vpp max.	10 kOhm / 2.6Vpp max.	10 kOhm / 2.6Vpp max.
Headphone Output	16 Ohm Minimum Load @ 21 mW	16 Ohm Minimum Load @ 21 mW	16 Ohm Minimum Load @ 21 mW

5 UNPACKING AND INSPECTION

5.1 UNBOXING

FLEX-6000 Signature series radios are double packed to protect your investment. To remove the radio, carefully cut the tape on one end of the outer carton and open the end flaps to expose the inner carton. Remove the inner carton by placing one hand on the inner carton while using the other hand to invert the outer box so the open end is facing down. Carefully place the inner carton on a flat surface then remove the outer carton by pulling up on the sides. Use caution not to let the inner carton slip out and fall.

Position the inner carton so the FLEX-6000 label is facing up. Carefully cut the tape and open the flaps exposing your radio. Remove the upper packing foam and set it aside.

I - Be sure to keep the carton and all packing material in case you ever need to ship your FLEX-6000.

5.2 VISUAL INSPECTION

5.2.1 General

Note the orientation of the radio in the packing foam. It is important that the front of the radio be properly aligned to prevent damage if further shipment is required. Remove the radio from the foam and the poly bag. Retain this bag if further shipment is required.

! - WARNING: POLY BAGS CAN BE A SUFFOCATION HAZARD. DO NOT LEAVE THIS BAG UNATTENDED AROUND SMALL CHILDREN!

Δ – CAUTION: THE POLY BAG IS VERY IMPORTANT TO PROTECT YOUR RADIO'S FINISH SHOULD YOU EVER NEED TO SHIP IT. DO NOT SHIP THE RADIO IN THE PACKING FOAM WITHOUT FIRST PLACING IT IN THE INCLUDED POLY BAG.

5.2.2 Radio

Inspect your FLEX-6000 radio for any physical damage due to rough shipment. Remove the protective cover from the front display.

5.2.3 Included Accessories

- One (1) FLEX-6000 Signature Series Unit (FLEX-6300, FLEX-6500, FLEX-6700 or FLEX-6700R)
- One (1) FHM-1 Microphone (optional for EU countries) (NA to FLEX-6700R)
- One (1) 6 ft. (1.8m) CAT 5 Ethernet cable
- One (1) DC power cord with Anderson Power Pole™ connectors (NA to FLEX-6700R)
- One (1) AC Power Cord / US (FLEX-6700R only)
- One (1) SmartSDR for Windows installation CD
- One (1) **FLEX-6000 Quick Start Guide** or **FLEX-6700R Quick Start Guide**
- One (1) Rack Mount Kit Option (if ordered)
- One (1) Handle Kit Option (if ordered)
- One (1) GPS patch antenna and RG-174 coax cable (if GPSDO ordered)

5.2.4 Additional Items not Included but Required

In addition to the supplied accessories, software and cables supplied with the FLEX-6000 Signature Series SDR, you will need to provide the following:

- An HF-Antenna or dummy load.
- An RF ground (if possible).
- Powered stereo speakers (computer type) or stereo headphones.
- A stabilized 13.8V DC power supply, capable of 25A or greater continuous duty.
- A Personal Computer (PC) running Windows Vista Service Pack 2 or above. Either 32 or 64-bit operating systems are supported (64-bit recommended).
- A 100/1000BaseT Ethernet Access – either an open port on your computer or on your local area network (LAN) Ethernet switch.

5.3 REPORTING DAMAGE

Please report any missing items or shipping damage to FlexRadio or your Distributor immediately. It is helpful to take digital pictures of the damage to assist in resolving the issue with the shipper. See the [CONTACT US](#) web page FlexRadio contact information. You can always open a HelpDesk Ticket at <https://helpdesk.flexradio.com>

6 FRONT PANEL CONTROLS AND CONNECTIONS

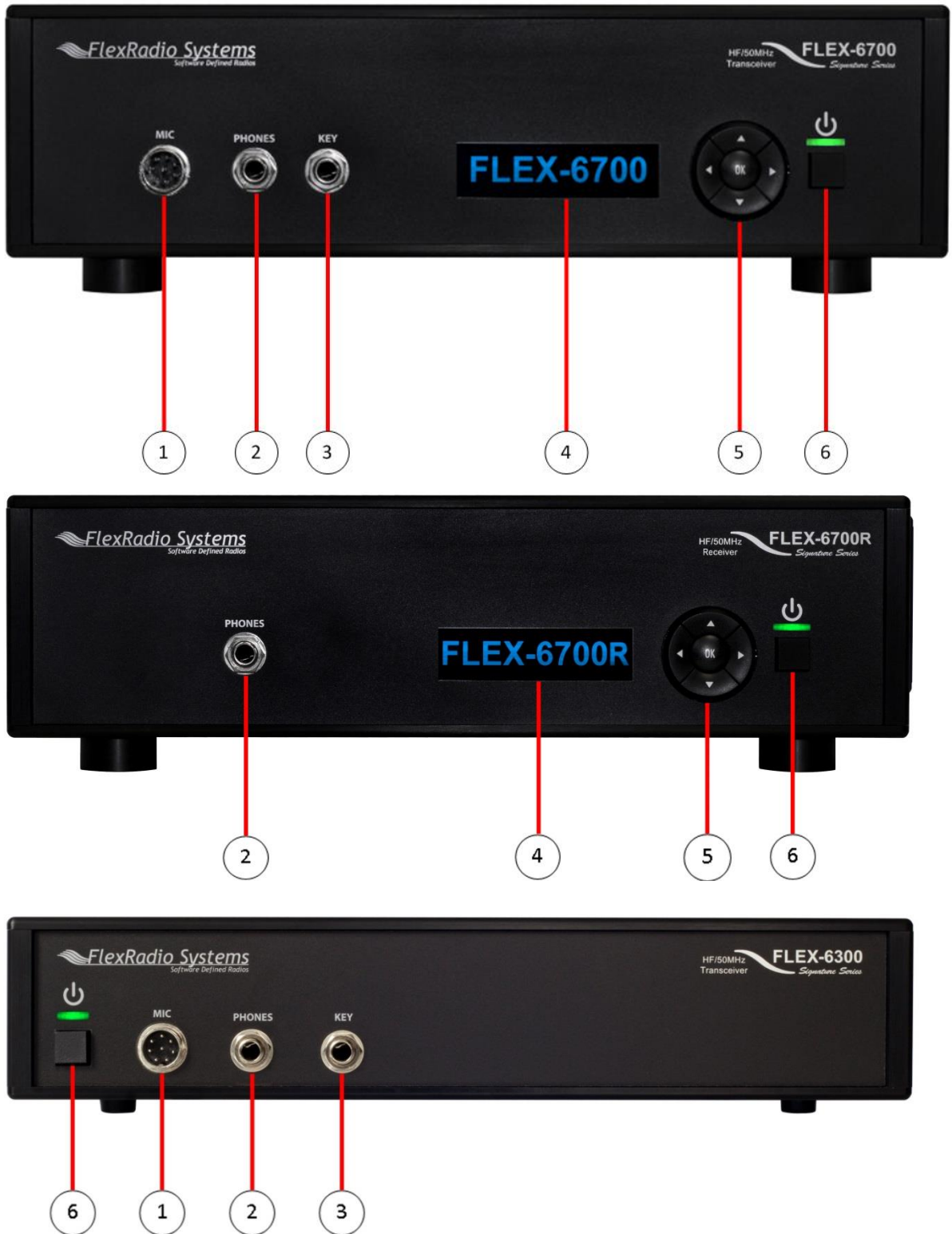

6.1 MICROPHONE JACK ¹

6.1.1 Connector Pinout

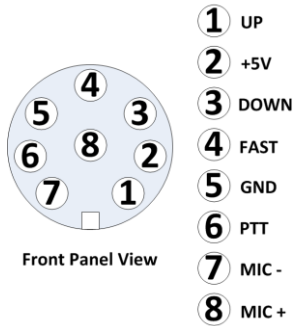

6.1.2 Supported Microphone Types

The FLEX-6000 front microphone connector can support either a dynamic or an electret microphone. This is a pseudo-balanced nominal 600 ohm impedance input. The electret bias voltage is not enabled by default, and must be enabled by SmartSDR. The supplied FHM-1 does not require the electret bias voltage to be enabled.

6.2 HEADPHONE JACK ²



The FLEX-6000 supports a stereo headset to allow for advanced audio routing features. The headphone jack is a ¼ inch TRS phone plug. Do not use a mono or TS connector that grounds the “ring” portion of the connector. There is a separate master headphone level control for the radio and LEFT-RIGHT (pan) slider control on each Slice Receiver. Refer to the [SmartSDR Software User’s Guide](#) for more information on controlling the audio to the headphone jack. Use high quality stereo headphones or a stereo communications headset for best results. Minimum headphone impedance is 16 ohms.

6.3 CW KEY/PADDLE JACK ³



The CW key/paddle jack is a ¼ inch TRS phone plug. For an iambic paddle, the tip is connected to the dot paddle, the ring is connected to the dash paddle and the sleeve is connected to the common. For a straight key or a keyer output, connect to the tip and leave the ring floating. The common is connected to the sleeve. (Note: 3.3VC Max input.)

6.4 MULTI-FUNCTION DISPLAY ⁴

The optical LED (OLED) multi-function display provides system level enunciator and troubleshooting information for your FLEX-6000.

6.5 NAVIGATION KEYS ⁵

The Navigation Keys may be used for advanced diagnostics in a future radio firmware release. Currently, the UP and DOWN navigation keys will brighten and dim the optical LED multifunction display.

6.6 MULTI-FUNCTION INDICATOR LED ⁶

The multifunction indicator LED is above the power pushbutton. It indicates the condition of the radio hardware and software.

6.6.1 Chart for Indicator Color Codes

SOLID BRIGHT RED: Transmitting on PA

SOLID ORANGE: Transmitting on XVTR port with low power

SOLID DIM RED: Transmit engaged, but transmit interlocks are not ready. Refer to SmartSDR documentation for description of transmit interlocks.

SOLID PURPLE: Radio is performing a software update

SOLID GREEN: Radio is in receive mode

FLASHING RED: Flashing three blinks indicates radio software is not running

FLASHING GREEN: Radio is booting or loading firmware

FLASHING WHITE: Radio is performing a reset to factory defaults

OFF: Radio turned off, oscillators are off.

6.6.2 Chart for Indicator Color Codes with optional GPSDO Installed

Note: These additional LED color codes only applies to the FLEX-6700, FLEX-6700R and FLEX-6500 with the optional GPSDO installed.

SOLID AMBER: Radio is powered off, GPSDO is powered for stability

FLASHING YELLOW: GPSDO is in warmup

SOLID YELLOW: GPSDO is in holdover (lost satellites)

SHORT FLASH BLUE: GPSDO is locking

LONG FLASH BLUE: GPSDO is in “hold phase” mode

SOLID BLUE: GPSDO is locked

6.7 POWER SWITCH 6

6.7.1 “Soft Power Control” Multiple Operations

The power control is a “soft power control” with multiple functions depending on the state of the radio. If the radio is powered off, momentarily pressing and releasing the button one time will start the radio software. It normally takes approximately thirty seconds from the button press until the radio is ready for SmartSDR. Refer to SmartSDR documentation for more information.

To shut down the radio, momentarily pressing and releasing the button one time will do an orderly shutdown of the radio software. When the button is pressed, the front panel LED will begin to flash green slowly. At the conclusion of the shutdown, the radio LED will either turn off or turn solid amber if a GPSDO is installed and the radio will shut off. This can take up to sixty seconds. It is advisable to allow the radio to shut down in this way. During a shutdown, the radio will save settings and so ending the shutdown early by removing power from the radio may cause a loss of settings.

Holding the power button down for 4+ seconds while the radio is running will trigger an immediate shutdown. This skips the database writing procedure so any changes will not be saved. This is not a recommended shutdown procedure for regular use.

FLEX-6700 and FLEX-6500 Reset Procedure

With the radio powered off, press and hold down the “OK” button on the front panel of the radio. Momentarily press and release the power button to power on the radio. Continue holding in the OK button until the front display counts down to 0, the power LED starts flashing white and the “CALIBRATING...” message is displayed, then release the OK button. Allow the radio to continue booting normally.

FLEX-6300 Reset Procedure

With the radio powered off, press and hold down the power button for approximately 5 seconds until the Power LED flashes white, then release the power button. Allow the radio to continue booting normally.

7 REAR PANEL CONNECTIONS

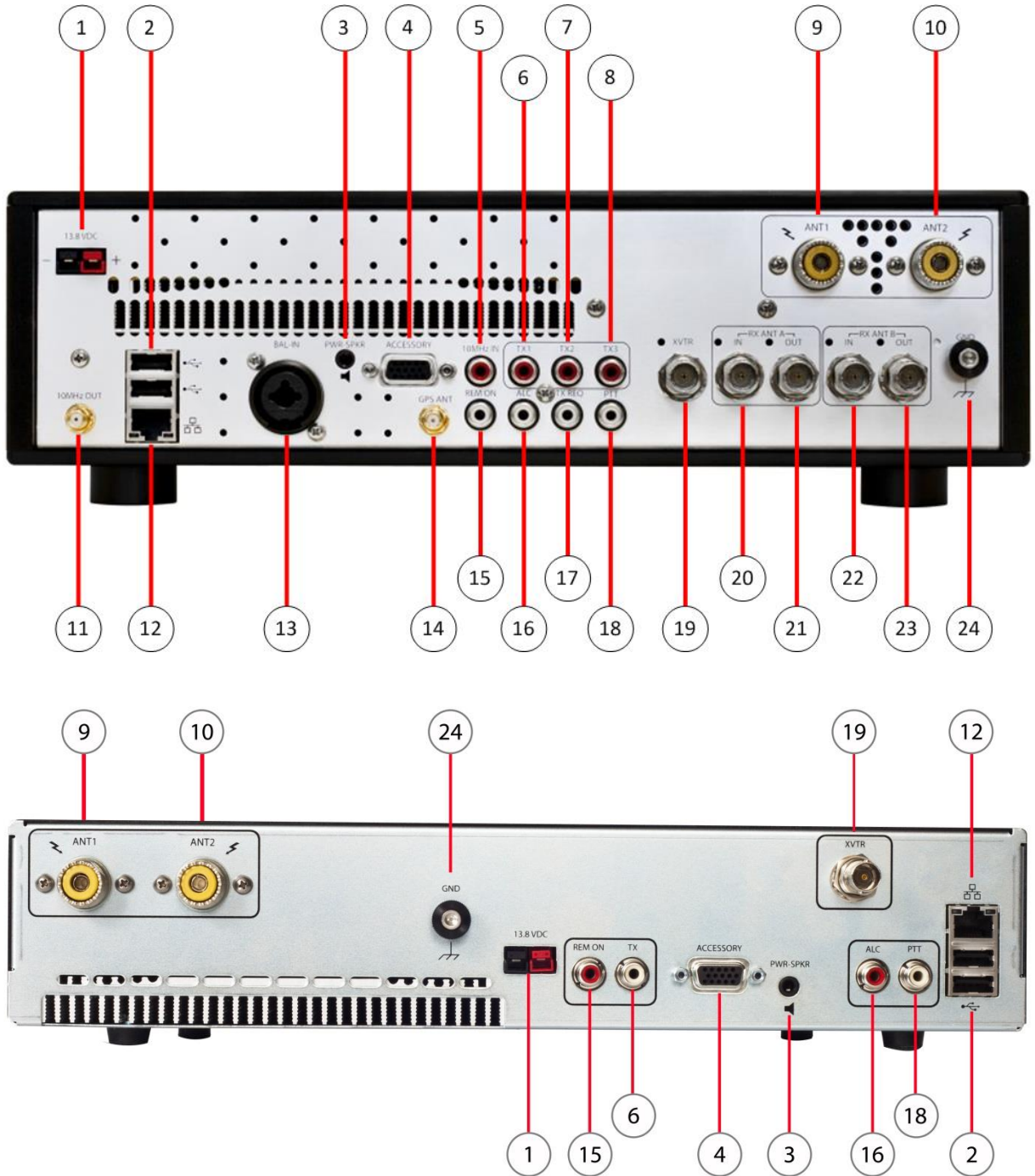

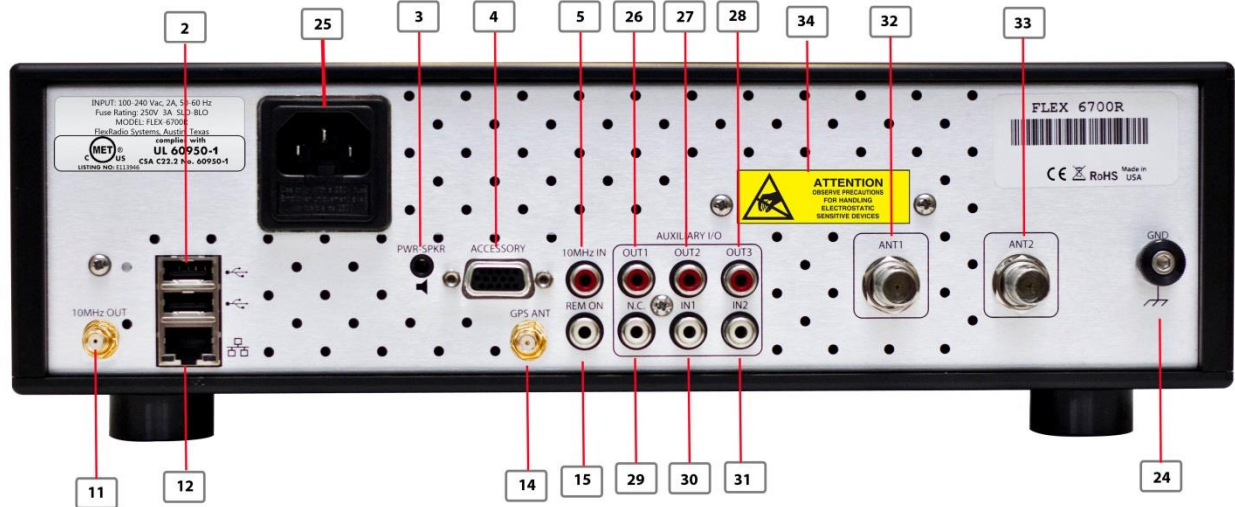

7.1 DC POWER INPUT ¹



The FLEX-6000 is designed to operate from a 13.8 volt nominal DC supply capable of supplying 25 amps of continuous current to the radio.

! – This unit must only be operated with the electrical power described in this manual. NEVER CONNECT THE +13.8VDC POWER CONNECTOR DIRECTLY TO AN AC OUTLET. This may cause a fire, injury, or electrical shock.

Δ – The FLEX-6000 requires 13.8 VDC @ 25 amps measured at the radio in order to transmit maximum wattage. Multiple power cable connections between the power supply and the FLEX-6000, a poorly regulated power supply, undersized power cable and very long power cable lengths will result in a voltage drop, especially under load. Any voltage deviation from 13.8 VDC will result in lower power output than the 100W nominal specification.

I - For best results, select a linear or switching power supply that is well regulated and free of internally generated noise. "Birdies" generated by a poorly filtered supply can often appear as signals in the SmartSDR Panadapter display.

7.1.1 Power Pole 30 Amp

The Anderson Power Pole™ connector contains 30 Amp pins to minimize voltage drop during transmit. The **RED** connection should be connected to the positive (+) lead of the power source. The **BLACK** connection should be connected to the negative (-) lead of the power source.

I - If you choose to use your own Power Pole cabling, be sure to properly size the wire and the Power Pole connector to minimize voltage drop during transmit. Excessive voltage drop can cause lower transmit power output levels.

7.1.2 Fused Internally at 30 Amps

The power input has a protective 30 Amp automotive “blade type” fuse inside the radio case. Should you ever need to replace the internal fuse, remove the top cover and locate the fuse in the rear corner of the PA board just inside the case adjacent to the Anderson Power Pole connector.

! – NEVER USE A FUSE WITH A CURRENT RATING HIGHER THAN 30 AMPS! FAILURE TO PROPERLY USE THIS SAFETY DEVICE COULD RESULT IN DAMAGE TO YOUR RADIO, POWER SUPPLY, OR CREATE A FIRE RISK.

7.2 USB 2.0 PORTS ²

The USB 2.0 ports are used for SmartSDR specific functions only. Do not connect unqualified USB devices to the FLEX-6000. Refer to the SmartSDR documentation for information about how these work.

7.3 POWERED SPEAKERS ³



The powered speaker connector is a 1/8” TRS stereo connector. Stereo powered computer speakers should be used with this connector. Tip is the left channel, Ring is the right channel and Sleeve is common. The audio level is a nominal standard consumer (-10 dBV) line level. Do not use a mono or TS connector that grounds the “ring” portion of the connector.

7.4 ACCESSORY CONNECTOR 4

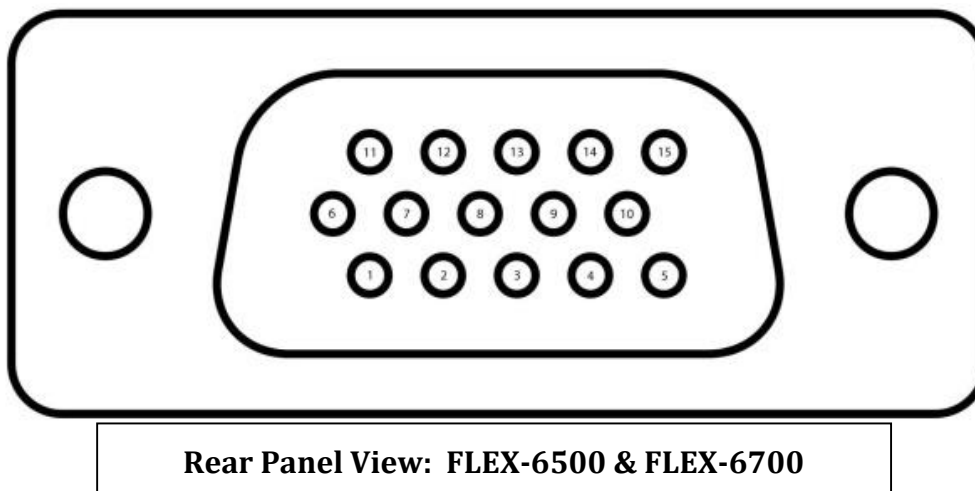

The accessory connector is a high-density HD-15 female connector. (This is the same connector used by VGA monitors.) There are a number of inputs and outputs on this connector.

I - The orientation shown above is for the FLEX-6500 and FLEX-6700 only. The FLEX-6300 is oriented upside down from what is shown above

Δ – All Accessory inputs are 3.3VDC MAX Input

7.4.1 Pin 1: Line In

This audio line input can be used to feed consumer level (-10dBV) audio into the transmitter. Refer to the SmartSDR documentation for information describing how to enable this input, and what configurations are available.

7.4.2 Pin 2: Line1 Out

This audio line output is a buffered output of the **POWERED SPEAKERS** left channel.

7.4.3 Pin 3: Line2 Out

This audio line output is a buffered output of the **POWERED SPEAKERS** right channel.

7.4.4 Pin 4: KEY/FSK/INT In

This input is a keying input for either CW or FSK. Refer to the SmartSDR documentation for information describing how to enable this input, and what configurations are available. Pin 4 is keyed to GROUND.

7.4.5 Pin 5, Reserved for future use (FLEX-6300 only)

On the FLEX-6300, pin 5 is not enabled and is reserved for future use.

7.4.6 Pin 5, Pin 6, Pin 7, Pin 8 and Pin 10: GROUND

These pins are all connected to chassis ground on the FLEX-6700 and FLEX-6500. Pin 5 is not a chassis ground for the FLEX-6300 (see above)

7.4.7 Pin 9: +5VDC

This pin is a +5VDC output for use by external equipment. This pin is capable of sourcing up to 500mA of current. A thermally resetting fuse will protect the radio from damage.

I - This pin is protected by a thermally protected fuse. If an over-current occurs, the fuse will open and remain open until the overload is removed.

7.4.8 Pin 11: Accessory TX

This pin is a buffered PTT output identical to the three RCA connectors TX1, TX2 and TX3. Refer to the SmartSDR documentation for information on how to configure this output.

7.4.9 Pin 12: SDA I/O

This pin is the data signal for an I2C serial communication channel. It is to be used with external equipment. Refer to the SmartSDR documentation for more information.

7.4.10 Pin 13: Accessory TX REQ

This pin is an additional transmit interlock signal input. Refer to the SmartSDR documentation for information on how to configure this input.

7.4.11 Pin 14: PTT in

This pin is a Push-To-Talk input. Ground Pin 14 to engage transmit.

7.4.12 Pin 15: SCL I/O

This pin is the clock signal for an I2C serial communication channel. It is to be used with external equipment. Refer to the SmartSDR documentation for more information.

7.5 10MHZ REFERENCE CLOCK INPUT 5

The external reference clock input is used to synchronize the radio's master oscillator. Requires a 1.0v p-p minimum to 3.3v p-p maximum (4dBm min - +15dBm max), sine or square wave signal.

7.5.1 Radio Oscillator Startup

The radio software samples the external clock input first, then the optional GPSDO (if present), then the internal oscillator (FLEX-6500: TCXO, FLEX-6700/6700R: OCXO). Once an active source is found, the radio software stops looking for any other clock source. If the external source is lost, the radio will look for an active internal oscillator, but it will not look for any other oscillator signal until the radio is powered off and re-started.

I - The external signal is only sampled at initial startup of the radio software. It is necessary to make the external signal available on the rear panel connector before the radio is powered up. Otherwise, the signal will not be used.

7.6 TX RELAY OUTPUTS [1,2,3] ⑥ ⑦ ⑧

TX1, TX2 and TX3 (TX on FLEX-6300) are outputs for keying external equipment such as amplifiers, external T/R switches, etc. They are all individual outputs, isolated from each other. Refer to the SmartSDR documentation for explanation on how to configure the timing for each output.

Δ – The TX Relay outputs are designed to handle signaling levels of up to +40 VDC @ 140 mA maximum. Some amplifiers do not have circuits to prevent keying voltage transients and older amplifiers may exceed the maximum voltage level resulting in damage to the radio if directly connected. Verify the voltage/current on your external device before connecting to TX Relay 1-3. FlexRadio highly recommends the use of a use a buffer/isolator box between the radio and the external device as a best operating practice regardless of the keying voltage.

7.7 TRANSCEIVER ANTENNA PORTS [1,2] ⑨ ⑩

Transceiver antenna ports are SO-239 50 ohm connectors. Refer to SmartSDR documentation for explanation on how to select which port is active.

! - WARNING: THE FLEX-6500 AND FLEX-6700 ARE CAPABLE OF GENERATING RF POWER LEVELS OF 100 WATTS. HIGH RF LEVELS WILL CAUSE SEVERE RF BURNS. NEVER TOUCH THE TRANSCEIVER ANTENNA PORT, AN EXPOSED COAXIAL CABLE END, OR A CONNECTED ANTENNA WHILE THE RADIO IS IN THE TRANSMIT MODE.

! – NEVER CONNECT OR DISCONNECT ANTENNAS WHILE IN TRANSMIT MODE. THIS MAY CAUSE ELECTRICAL SHOCK OR RF BURNS TO YOUR SKIN AND DAMAGE TO THE UNIT.

! – THIS UNIT GENERATES RADIO FREQUENCY (RF) ENERGY. USE CAUTION AND OBSERVE PROPER SAFETY PRACTICES REGARDING YOUR SYSTEM CONFIGURATION. WHEN ATTACHED TO AN ANTENNA, THIS RADIO IS CAPABLE OF GENERATING RF ELECTROMAGNETIC FIELDS WHICH REQUIRE EVALUATION ACCORDING TO YOUR NATIONAL LAW TO PROVIDE ANY NECESSARY ISOLATION OR PROTECTION REQUIRED, WITH RESPECT TO HUMAN EXPOSURE!

7.8 10MHZ REFERENCE OUTPUT (W/GPSDO OPTION) ⑪

If the radio has the optional GPSDO, the 10 MHz reference output is a buffered 3.3V p-p output of the 10 MHz oscillator in the GPSDO. The signal can be used to provide a reference signal for external equipment. The connector is a female SMA.

Δ – CAUTION: USE CARE IN ATTACHING OR REMOVING SMA CONNECTORS. BEST PRACTICE IS TO HOLD THE COAX WITH ONE HAND WHILE TWISTING THE SMA CONNECTOR SHELL WITH THE OTHER. ONCE THE MALE AND FEMALE CONNECTORS MATE, TURN UNTIL SNUG BUT DO NOT OVER TIGHTEN!

7.9 ETHERNET CONNECTOR 12

This is the network connection for the radio. It is an auto-sensing 100 megabit or 1 gigabit Ethernet port. It auto-senses polarity as well, so if you are using a direct connection to your PC, you do not need a crossover cable. Refer to the SmartSDR documentation for information as to the network configuration options.

7.10 BALANCED AUDIO INPUT 13

This is a balanced audio input for the radio and will produce the highest quality audio transmission. It can be used as a microphone level input, or a line level input. It can accept a ¼" TRS Phone Plug, or a male XLR connector. Refer to SmartSDR for Windows documentation for information on how to select the microphone and line level on this connector.

7.10.1 Balanced Audio Input Connectors

TRS Connector		
Contact	Description	Connector
Tip	Positive phase for balanced mono signals or mic (+)	
Ring	Negative phase for balanced mono signals or mic (-)	
Sleeve	Ground or shield connection	

XLR Male Connector		
Contact	Description	Connector
Pin 1	Ground or shield connection	
Pin 2	Positive phase for balanced mono signals or mic (+)	
Pin 3	Negative phase for balanced mono signals or mic (-)	

7.10.2 MIC vs. LINE Use

The balanced input can be used as a microphone level or a line level audio input. The microphone level is suitable for a dynamic microphone. The balanced input does not have any DC bias capability. If your microphone requires bias power (5VDC) or phantom power (48VDC), an external power supply is required.

7.10.3 Line Level

There are a number of different definitions of “line level”. The audio input device in the FLEX-6000 series radios is designed for a “consumer line level” specification. This is defined as -10 dBV. If you plan to use “professional line level” devices to feed your radio, you will need to reduce the output level so that it does not exceed the -10 dBV level (-8 dBu). The hardware input will clip around 0 dBm (~-2.2dBV).

7.11 GPS ANTENNA INPUT (W/GPSDO OPTION) 14

If the radio is equipped with the optional GPSDO, this female SMA connector is for connecting the included GPS antenna. The GPSDO provides DC bias for the antenna preamp. It can work with antennas that require either 3.3 Volt or 5 Volt DC bias.

7.12 REMOTE POWER ON INPUT 15

This RCA connector is provided for remote power-on functionality. When the Remote Power ON feature is enabled, shorting this input to ground will activate the radio - opening this connector will disable power on the radio. Refer to the SmartSDR documentation for information on how to configure this input. (Note: 3.3VDC Max Input.)

7.13 EXTERNAL AMPLIFIER ALC INPUT 16

This RCA connector is provided to receive an ALC signal from an external amplifier. The shell is ground, and the pin is a negative going DC voltage, zero to -4 Volts.

! – VOLTAGES BELOW -4VDC MAY DAMAGE THE ALC INPUT.

Δ – Please note this input is provided as a safety measure for external amplifiers. It is NOT meant to be used in regular operation as an active power control input or to modify the “attack” of an external amplifier. Almost all modern HF amplifier manufacturers discourage the use of ALC in normal operation. In fact, many amplifiers do not have ALC implemented. The [SmartSDR Software User’s Guide](#) describes the recommended method for setting the power level on an external amplifier on a per-band basis.

7.14 TX REQUEST INPUT (INTERLOCK) 17

This RCA connector is provided to receive an interlock signal from external amplifiers, or other external equipment. When enabled it will prevent the FLEX-6000 from going to transmit. The TX Request Input can be enabled with a 3.3V to 5V logic signal. The circuit is a 74LVC14 CMOS Schmidt trigger logic input with a 2.7k pullup to +3.3V. The IC is 5V tolerant so you can drive it with TTL levels as well. It can also be driven with an open collector transistor or open drain MOSFET. Grounding the center pin of this connector will prevent transmit from engaging. Refer to the SmartSDR documentation for information about how the interlock system works and how to determine what is preventing transmit.

7.15 PTT INPUT 18

This RCA connector is provided for an external Push-To-Talk signal. Ground the center pin of this RCA to engage PTT. (Note: 3.3VDC Max. Input.)

7.16 TRANSVERTER PORT 19

This female BNC connector is a receiver input and low-level exciter output for use with Transverters. Refer to the SmartSDR documentation for information regarding using the FLEX6000 with external Transverters.

I - The XVTR port can also be used as an auxiliary receive antenna connection when not being used for transverter operation.

7.17 RX ANT-A RF INPUT 20

This female BNC connector is a direct feed to the input of the first Spectral Capture Unit (SCU-A) in the radio. This is a dual use connection: (a) for use as a RECEIVE ONLY input to the RXA SCU and (b) to be used with the **RX ANT-A RF OUTPUT**, creating a user-switchable RX only signal path “loop” (output/input) associated with the assigned ANT port for adding an external filter or preamplifier. Refer to the SmartSDR documentation for information describing how to select this input, and how it can be used.

7.18 RX ANT-A RF OUTPUT 21

This female BNC connector is an output from the antenna feeding SCU-A. This signal is paired with RX ANT-A INPUT (Sec. 7.17). Refer to the SmartSDR documentation for information describing how this output is configured and how it can be used.

Δ – Please note this input is not protected by the FLEX-6000 ESD circuitry. Any device connected to the RX ANT-A Output is susceptible to possible damage by ESD from an EMP event if the connected device does not have adequate ESD protection circuitry.

7.19 RX ANT-B RF INPUT (FLEX-6700/6700R ONLY) 22

This female BNC connector is a direct feed to the input of the Second Spectral Capture Unit (SCU-B) in the radio. This is a dual use connection: (a) for use as a RECEIVE ONLY input to the RXB SCU and (b) to be used with the **RX ANT-B RF OUTPUT**, creating a user-switchable RX only signal path “loop” (output/input) associated with the assigned ANT port for adding an external filter or preamplifier. Refer to the SmartSDR documentation for information describing how to select this input, and how it can be used.

7.20 RX ANT-B RF OUTPUT (FLEX-6700/6700R ONLY) 23

This female BNC connector is an output from the antenna feeding SCU-B. This signal is paired with RX ANT-B INPUT (Sec. 7.17). Refer to the SmartSDR documentation for information describing how this output is configured and how it can be used.

Δ – Please note this input is not protected by the FLEX-6000 ESD circuitry. Any device connected to the RX ANT-B Output is susceptible to possible damage by ESD from an EMP event if the connected device does not have adequate ESD protection circuitry.

7.21 CHASSIS GROUND ⁽²⁴⁾

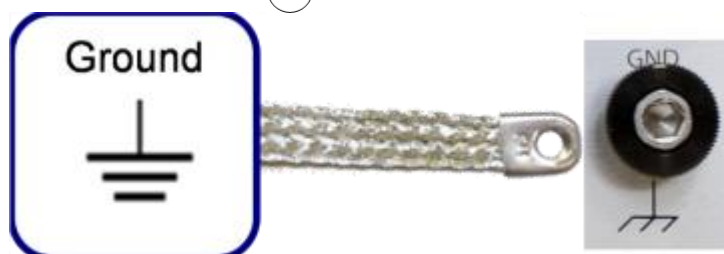

This is a thumbscrew for attaching an earth ground to the chassis of the radio. Grounding is the most important safety enhancement you can make to your shack. Always ground the FLEX-6000 to your station RF ground using high quality wiring with the length being as short as possible. Braided wire is considered the best for ground applications. Your station ground should be a common point where all grounds come together. You will likely be using a PC and a DC power source so be sure to ground these devices together as well.

7.22 AC POWER INPUT ⁽²⁵⁾

AC power input connection at 100 – 240V, 50 – 60 Hz. 3 Amp fused. Power cord provided. FLEX-6700R only.

! – CAUTION: DOUBLE POLE/NEUTRAL FUSING! - FUSES LOCATED IN POWER ENTRY MODULE. DISCONNECT THE UNIT FROM THE POWER OUTLET AND REMOVE THE POWER CORD FROM THE UNIT PRIOR TO MAINTENANCE AND SERVICING.

(IN DENMARK: “APPARATETS STIKPROP SKAL TILSLUTTES EN STIKKONTAKT MED JORD, SOM GIVER FORBINDELSE TIL STIKPROPPENS JORD.”)

7.23 OUTPUTS [1, 2, 3] ⁽²⁶⁾ ⁽²⁷⁾ ⁽²⁸⁾

Open drain digital outputs. Possible future product feature - not currently enabled.

7.24 NO CONNECTION (NC) ⁽²⁹⁾

This port is not used on the FLEX-6700R.

7.25 DIGITAL INPUTS [1, 2] ⁽³⁰⁾ ⁽³¹⁾

Digital inputs @ 3.3v logic. Future product feature. Not currently enabled.

7.26 ANTENNA INPUTS [1, 2] ⁽³²⁾ ⁽³³⁾

Antenna connections: 50 Ohm input. Refer to SmartSDR for Windows documentation for explanation on how to select which port is active.

7.27 ATTENTION LABEL ⁽³⁴⁾

“Warning: All input/output connections, including front panel I/O connections, may be static sensitive.”

8 INSTALLATION

8.1 SAFETY

Since your FLEX-6000 will likely be connected to many different antenna and external interface conditions, safety is an important factor in your station setup. In addition to grounding mentioned earlier, proper Electro-Static Discharge (ESD) and lightning protection should be employed. It is outside the scope of this manual to go into details regarding proper ESD protection. Please follow good amateur practice to protect yourself and your investment.

8.2 RADIO PLACEMENT

Proper placement of your FLEX-6000 is important for maximum reliability. For proper ventilation, place your radio on a hard surface in a dry area with at least 1" of clearance on each side of the radio to allow for optimal fan operation and 2" behind the radio for cabling clearance. An optional 19" rack mount kit is available for mounting.

8.3 ENVIRONMENTAL CONSIDERATIONS

This radio is designed for indoor operation in a clean dust free environment. Try to avoid areas of wide temperature extremes. This includes placing the sides of the radio too close to the hot exhaust of an external amplifier. Should the temperature inside the radio become too high, the fans will automatically increase to a higher speed. (Note this can happen after long periods of transmit.)

Δ - Do not operate this unit in areas of extreme humidity.

Δ - Avoid operating this radio in direct sunlight or other areas of extreme heat, excessive vibration, or mechanical force.

8.4 CONNECTING TO A PC

8.4.1 Ethernet Cabling Requirements

The FLEX-6000 is designed to use CAT5, CAT5e, or CAT6 Unshielded Twisted Pair (UTP) network cabling. If you need to make a network connection that is longer than the included cable, be sure to use high quality cable. Note that the Ethernet specification requires the cable to be less than 100 meters in length before a repeater or switch is required. You should avoid the use of Shielded Twisted Pair (STP) type Ethernet cables. The shield can provide a noise return path that can adversely affect receiver performance.

Δ – As mentioned earlier, proper Electro-Static Discharge (ESD) and lightning protection should be employed. It is outside the scope of this manual to go into details regarding proper ESD protection. However, it's important to note that this radio could be connected to a potential ESD threat that you aren't used to: the Ethernet connection. Many times, adjacent ESD and lightning can enter a shack over the power, cable, or telephone lines. The ESD will then "jump" your Internet modem device and travel throughout the house on the Ethernet cable. A small investment in a 100Mbit Ethernet Surge/Lightning Suppressor could save your expensive FLEX-6000 from damage.

8.4.2 Direct PC Connection (Link-Local)

The simplest method to connect your PC to your FLEX-6000 is using a Link-Local connection. Simply plug the included Ethernet cable into the FLEX-6000 and then directly into the network connection on your PC, Microsoft Windows™ will recognize your radio and establish a local only connection. When the radio is activated, it will begin to broadcast it's presence on the Link-Local connection. Note that in Link-Local mode, your radio will not be connected to or available to any other network connections on your PC.

I - It is not necessary to use a "crossover" Ethernet cable to establish a Link-Local connection with the FLEX-6000. The Ethernet interface on the radio has a smart sensing feature that will detect a Link-Local connection and make the proper adjustments internally.

8.4.3 Connecting via a Local Network

The most versatile method to connect your PC to your FLEX-6000 is to connect your radio to your existing local area network (LAN). Using the included Ethernet cable (or another appropriate cable), plug one end into the FLEX-6000 Ethernet port and the other end into your existing Ethernet switch or home router. With this LAN connection, your radio will automatically receive a network IP address and begin broadcasting it's presence with the radio is activated. The advantage of the LAN connection is that all PCs on your LAN can have access to the radio.

8.4.3.1 Network Configuration Considerations

There are several considerations when connecting your FLEX-6000 radio to your existing LAN:

- Your LAN must be configured to supply a network address to the radio. This is known as Dynamic Host Control Protocol (DHCP). Most LANs do this by default. If you can simply plug multiple PCs into your LAN to connect to the internet, your LAN is very likely set up to serve DHCP to the radio.
- Even though the FLEX-6000 is capable of operating in Gigabit, 100Mbit, and 10Mbit LAN environments, FlexRadio highly recommends a minimum 100Mbit LAN environment. **Note that you can easily overload a 10Mbit LAN or LAN component with FLEX-6000 running multiple panadapters and receivers.**

8.4.4 Installing SmartSDR

SmartSDR is the operating software that runs along with your FLEX-6000 to provide the human interface to your radio. Please refer to the **FLEX-6000 Quick Start Guide** or the **FLEX-6700R Quick Start Guide** and **SmartSDR Software User's Guide** for information regarding installation, configuration, and operation of your radio with this software.

9 FHM-1 MICROPHONE

The FLEX-6000 may include the FHM-1 dynamic microphone depending on radio model or the country of purchase. The FHM-1 is a communications grade hand mic.

9.1 SPECIFICATIONS

Element Type: Dynamic

Impedance: ~200 ohm \pm 30% @ 1 kHz (Tone setting in position 1)

Sensitivity: -79 dB \pm 3dB @ 1 kHz

Frequency Response (Tone 1): full range (preferred setting)

Frequency Response (Tone 2): -14 dB \pm 3dB @ 100 Hz

9.2 TONE SWITCH

The FHM-1 microphone has a tone control switch on the back of the microphone that is used for adjustment of the microphone's frequency response.

Setting the Tone switch to the "1" (left) position will enable a wider frequency response, resulting in higher fidelity audio. It is recommended that the Tone switch be set in the 1 position and use the software EQ to tailor the tonal qualities of the microphone with your voice.

Setting the Tone switch to the "2" (right) position will roll off the bass frequency response resulting in more audio energy in your transmitted signal providing for optimum articulation desired for DX/communication quality audio. However the same effect can be achieved by setting the Tone switch to the 1 position and using the software EQ to reduce frequencies in the 50-400 Hz range.

9.3 BEST PRACTICES

To achieve the optimal fidelity from the FHM-1 microphone the following best practices are recommended.

Keep the microphone 1-2 inches away from your mouth. All microphones including the FHM-1 experience the proximity effect, where the closer you talk to the mic, the lower frequencies are amplified providing a higher fidelity frequency response.

Cross talk the microphone. Unfortunately talking close to the mic also amplifies other sounds that can result in picking up breathing noises (low rumble) and plosive sounds from certain words. To minimize the effect, speak across the front of the mic and not directly into it.

Set the Tone Switch to the 1 Position: It is best to set the FHM-1 for full range operation and make audio quality adjustments using the software EQ and by adjusting the low and high cut values of the transmit filter.

10 TRANSVERTER SETUP

Transverters allow both reception and transmission on frequencies not available in your base FLEX-6000 radio. The transverter translates RF at one frequency to another for both transmit and receive. Generally, the transverters will have an RF side that is in the VHF or microwave region and an IF side in the HF or low VHF side. An example transverter block diagram is shown below:

EXAMPLE TRANSVERTER APPLICATION

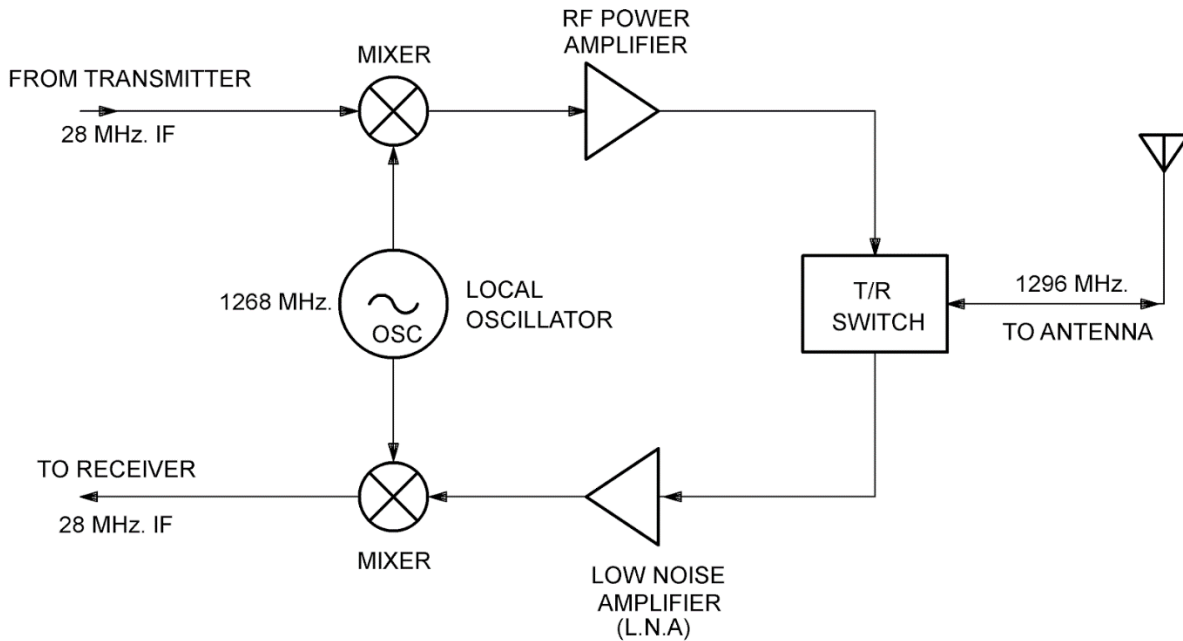

Copyright FlexRadio Systems 2014

This transverter converts from 10m RF signals (28MHz) to 1296MHz RF signals and back. The transverter shown in the picture has three RF connectors:

RX IF - the 10m receive port

TX IF - the 10m transmit port

RF - the RF input and output that goes to an antenna

This type of transverter is called a “Split IF” transverter since the IF side of the transverter has both a receive and a transmit port. The other type of transverter is a “Common IF” transverter where a relay internal to the transverter is used to switch a single IF port between receive and transmit. The table below shows the compatibility between transverter types and the FLEX-6000 family.

Radio Model	Split IF	Common IF
FLEX-6300	No	Yes
FLEX-6500	Yes	Yes
FLEX-6700	Yes	Yes

If the event that you have a FLEX-6300 and split IF transverters, you can still use your transverters, but you must supply a relay that effectively converts from a split IF to a common IF transverter. The FLEX-6300 cannot directly support a Split IF transverter since it only has one transverter or receive port.

10.1 TRANSMIT POWER CONSIDERATIONS

The default transverter output is 0 dBm. The FLEX-6000 can produce an output on the XVTR port up to +8 dBm for IF frequencies above 135MHz (FLEX-6700) or up to +15dBm for frequencies below 72MHz. If your transverter requires a higher level input than this, it is recommended that you either modify the transverter for a lower power input or provide an amplifier to amplify the transmit signal before passing to the transverter.

10.2 RF CONNECTIONS - COMMON IF

For a common IF configuration, the Common IF port of the transverter should be connected to the XVTR port on your FLEX-6000. This will be the only RF connection between the transverter and the radio.

10.3 RF CONNECTIONS - SPLIT IF

For split IF transverters, the TX IF of your transverter should be connected to the XVTR port on the FLEX-6000. The RX IF port should be connected to either RX-A or RX-B (FLEX-6700). As mentioned previously, the FLEX-6300 requires either a common IF transverter or a relay that can be used to convert a split IF transverter to a common IF transverter.

While it is technically feasible to use the ANT1 or ANT2 ports for receive, this is not recommended since these ports can produce high-power RF at any time that could damage your transverter.

10.4 PTT CONNECTIONS

The radio will need to provide a PTT signal to place the transverter into transmit mode. Most transverters will have a grounded-PTT input. This should be connected to a FLEX-6000 TX1, TX2 or TX3 output to cause the transverter to transmit. Depending on the design of the transverter, a weak pull-up may be required.

10.5 SEQUENCERS

In some transverter applications, notably those that include a split RF output, preamplifiers and/or power amplifiers, a sequencer may be used. The specific details of connecting and configuring a sequencer are beyond the scope of this document, but the TX1, TX2 or TX3 output from the radio are generally used as an input to the sequencer to allow it to properly switch and enable/disable each component in your lash-up.

10.6 MULTIPLE TRANSVERTERS

At this time, no band data is provided by the radio and this may provide an effective limit of one transverter at a time. FlexRadio anticipates adding band data in a later release of SmartSDR that would assist remote switching hardware in selecting between multiple transverters.

11 DIGITAL MODE SETUP (SOUND CARD INTERFACE)

There are two options for operating digital modes with the FLEX-6000 Signature Series SDRs. The *preferred* method does not use a physical sound card connection; it uses DAX (Digital Audio eXchange) where the audio is streamed digitally between the radio and client software over the Ethernet connection via the IP/UDP protocol. This method eliminates unnecessary analog to digital and digital to analog conversions which degrades signal to noise ratio performance.

You may also operate digital modes in essentially the same manner as most analog/DSP radios where analog audio from the speakers and to the microphone input is interfaced with a PC sound card. The following procedure can be used for operating digital modes with the FLEX-6000 interfaced to a sound card.

This procedure assumes that you have a working knowledge of operating digital modes with your favorite sound card based digital mode program and will not delve into the details of configuring specific third-party digital mode programs. Connecting the FLEX-6000 to a PC sound card

There are several audio inputs and outputs on the FLEX-6000 that can be used for connecting the radio hardware to a PC sound card. Please refer to the [FLEX-6000 Software User's Guide](#) for a detailed description on configuring and enabling digital modes.

The basic audio schematic is used to connect a FLEX-6000 to a PC sound card:

PC Sound Card Mic / Line In <---> FLEX-6000 Audio Output
PC Sound Card Line Out / Speaker Out <---> FLEX-6000 Audio Input

FLEX-6000 Inputs:

Front Mic Connector [MIC] (8-pin Foster)
Rear Balanced Input [BAL] (3-pin XLR) (Not available on FLEX-6300)
Rear Line Input [LINE] (1/4" TRS connector) (Not available on FLEX-6300)
Rear Accessory input [ACC] (15-pin D-sub connector)

FLEX-6000 Outputs:

Front Headphone connector (1/4" TRS connector)
Rear Powered Speaker connector (1/8" TRS connector)
Rear Accessory output (15-pin D-sub connector)

The audio input and output you choose is mostly a matter of your operating preferences. For example, if you also operate phone modes, you may not want to constantly disconnect your microphone and speakers to facilitate the connection to the PC sound card, so you may want to use the Accessory connector for both the audio input and output. In the following example, the left channel audio output on the Accessory connector is used to facilitate both the input and output audio connections to the PC sound card.

When connecting the FLEX-6000 to a PC sound card, connect one of the FLEX-6000 inputs to the LINE OUT on the sound card and one of the FLEX-6000 outputs to the MIC or LINE IN on the sound card.

12 ANTENNA CONSIDERATIONS

The FLEX-6000 Series radios incorporate a unique smart antenna switching matrix to simplify connections from your radio to your station antennas. Below are the signal flow diagrams for the FLEX-6500 and FLEX-6700 transceivers:

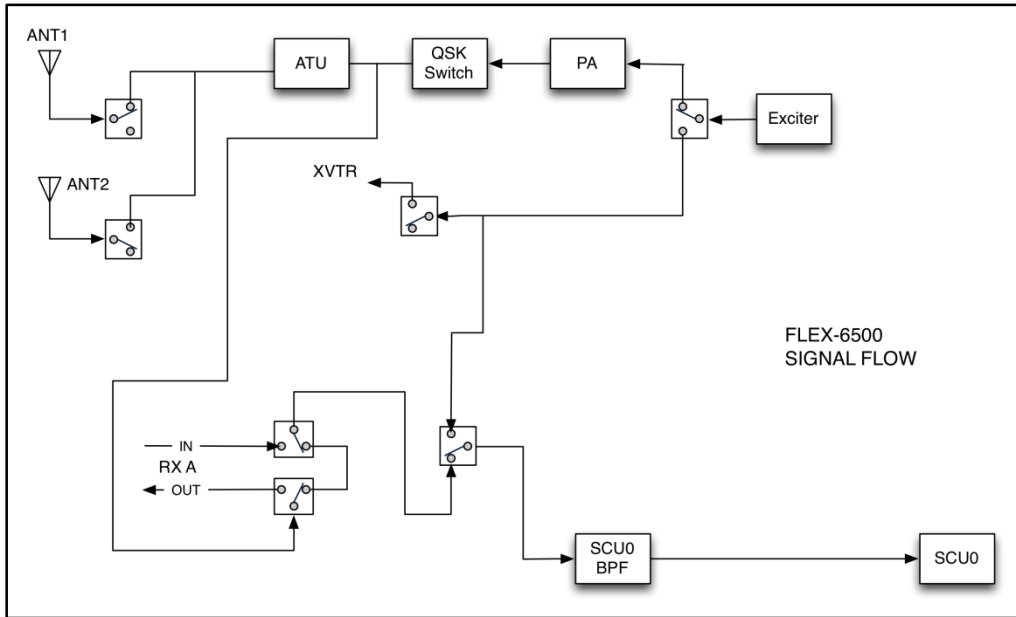
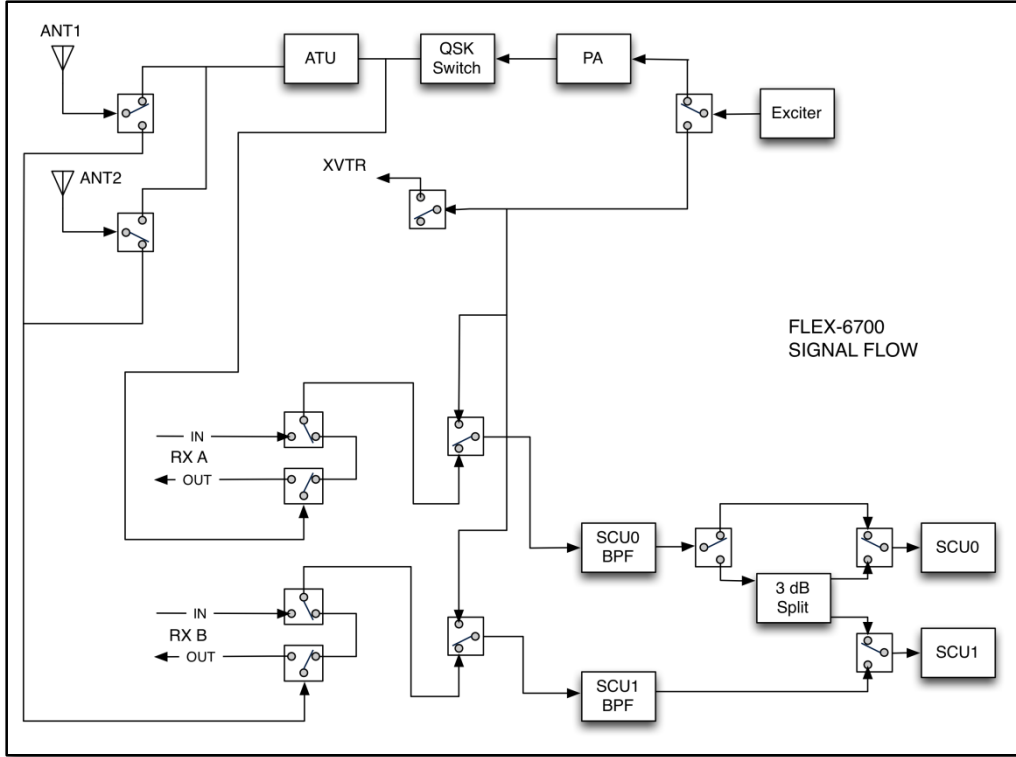

- ANT1 and ANT2 can be used for transceive operation. RX ANT-A (and RX ANT-B on FLEX-6700) are for receive only but can be paired with ANT1 or ANT2 for split antenna operation. The XVTR port can be used for transverter operation or as an additional receive antenna port.
- Signals from ANT1 and ANT2 can be “looped” through external filters and pre-amplifiers for additional system flexibility. THE ANT1/2 incoming signal is routed to the RX ANT-A OUT port then to the remote device. The modified signal is returned to the radio via the RX ANT-A IN port then to SCU-A. For the FLEX-6700, the RX ANT-B “loop” is available also.
- FOR very high speed CW above 60WPM (QRQ mode), separate receive and transmit antennas should be used to remove any switching delays. The transmit antenna must be connect to ANT-A or ANT-B and the receive antenna must be connected directly to RX ANT-A or RX ANT-B INPUT.

Consult the **SmartSDR Software User’s Guide** for a complete description of the operation and configuration of the FLEX-6000 antenna matrix system.

12.1 ANTENNA SELECTION

The unique ability of the FLEX-6000 to receive continuously over a very wide bandwidth opens up a new paradigm in amateur transceiver operation. This also changes how you might consider the proper antenna for your station operation. First, it’s important to note that almost EVERY properly installed antenna will work adequately as a broadband receive antenna; even single band Yagi antennas work quite well across the amateur bands. Start by experimenting with your existing antennas to see how well they work!

For added performance across a wider frequency range, consider adding a broadband receive antenna such as a beverage, long wire, log-periodic, traditional or shielded loop, or multi-band dipole, yagi, or vertical. Using the antenna matrix, you can receive over a wide range, and then use your tuned narrowband antennas for transmitting. Consult the **SmartSDR Software User’s Guide** for antenna configuration.

13 ANTENNA TUNER UNIT (ATU)

The FLEX-6000 automatic antenna tuner unit (ATU) is an antenna matching network designed to present a 50 ohm, low SWR load to the power amplifier (PA) for efficient RF power transfer on non-resonant antenna systems.

The FLEX-6700 and FLEX-6500 have an integrated ATU as a standard feature whereas the ATU for the FLEX-6300 is a user installable option.

13.1 SPECIFICATIONS

Network Type: L Network

Antenna Connection: Unbalanced (coax)

Frequency Range: 1.8 to 54 MHz

VSWR Range: 8.3 - 300 Ohms (80m – 10m)

6.7 - 150 Ohms (160m and 6m)

Tune Power: 10W / 2W on 6m (automatically set by software)

Δ – It is not recommended to attempt repeated tuning of antennas with the ATU connected to antenna systems that exceed the maximum VSWR on a frequency of interest. Some antenna systems, such as physically short multiband antennas may exhibit a very narrow range of resonance (a high Q antenna) in addition to being very reactive. The FLEX-6000 ATU is not designed to tune these types of antenna systems. An external antenna tuner that is designed to handle a wider VSWR range is recommended for these types of antennas.

14 OPTIONAL GPS DISCIPLINED OSCILLATOR (GPSDO) SETUP

14.1 GPSDO INTRODUCTION

The FLEX-6700 and FLEX-6500 Signature Series radios have the ability to attain extremely precise frequency control through the use of an optional Global Positioning System Disciplined Oscillator (GPSDO) module. After satellite acquisition and synchronization, the GPSDO is capable of maintaining frequency accuracy to $<5.0 \times 10^{-12}$ in a stable temperature environment.

14.2 GPS ANTENNA PLACEMENT

In order for the GPSDO to function properly, the indoor GPS receiver antenna must be positioned so it has an un-obstructed view of the sky in order to receive timing information from the GPS satellite constellation. While the best location for a GPS antenna is outside in the clear, most of the time simply placing the indoor antenna in a window will suffice. In general, the better the view of the sky (south in the northern hemisphere and north in the southern hemisphere), the quicker the GPS will lock to a high accuracy level. Some experimenting may be required to find the optimal location.

I - The included low profile GPS antenna is not waterproof, therefore it is not suitable for outdoor use.

I - The included low profile GPS antenna may be marked with the word "PULSE". This is actually the BOTTOM of the antenna and should be placed down and away from the sky. An included adhesive tape strip is available for permanently affixing the GPS antenna to a window sill or outside location.

Δ – CAUTION: USE CARE IN ATTACHING OR REMOVING SMA CONNECTORS. BEST PRACTICE IS TO HOLD THE COAX WITH ONE HAND WHILE TWISTING THE SMA CONNECTOR SHELL WITH THE OTHER. ONCE THE MALE AND FEMALE CONNECTORS MATE, TURN UNTIL SNUG BUT DO NOT OVER TIGHTEN!

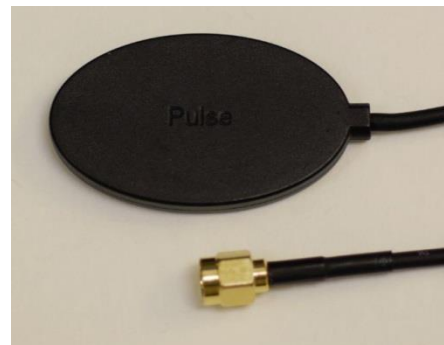

14.3 GPSDO LOCK SEQUENCE AND STATUS INDICATORS

(Please consult the **SmartSDR Software User's Guide** for a complete description of the on-screen displays and software setup of the GPSDO.

Upon FLEX-6000 initialization, the radio will sense a GPSDO module is installed and switch from the default oscillator to the GPSDO reference output signal. The MULTIFUNCTION STATUS INDICATOR (MSI) will illuminate FLASHING YELLOW to indicate the GPSDO is in “warmup” mode.

Once satellites are acquired and the synchronization process has begun, the MSI will change to a SHORT FLASHING BLUE to indicate “locking” mode.

Upon reaching full “locked” mode, the MSI will go to SOLID BLUE. Once locked, the GPSDO may re-synchronize occasionally due to satellite changes. A LONG FLASHING BLUE will indicate this “hold phase”.

If GPS satellites are no longer visible, the GPSDO will enter “holdover” mode and the MSI will indicate SOLID YELLOW. The radio will continue to be completely functional but the frequency accuracy could diminish to $\pm 2 \times 10^{-8}$ over time. The GPSDO is configured to remain “powered” even when the radio is off. This maintains frequency accuracy of the GPSDO. The MSI shows SOLID AMBER.

I - Initial GPS acquisition and synchronization can take up to 1 hour depending upon antenna placement and your location on Earth. This is normal and the radio is fully functional during this process.

I - GPSDO self-installation is possible and is covered in a separate installation manual included with the GPSDO OPTION KIT.

15 CALIBRATION

The FLEX-6000 is extensively calibrated, aligned and tested as part of the manufacturing and quality assurance processes. The FLEX-6000 also performs self-calibrations every time the radio is powered up. In general, there are a limited number of hardware calibrations that can be performed by the user, but the one available is listed below.

15.1 FREQUENCY CALIBRATION

The FLEX-6000 incorporates high quality low phase noise TCXOs and OCXOs for frequency accuracy and stability. However oscillators undergo a slow gradual change of frequency with time, known as aging and may require periodic frequency calibration using a known frequency standard.

The FLEX-6000 *without* an installed GPSDO can be calibrated by the user utilizing the automated routine provided in the SmartSDR for Windows client software. Before running this calibration routine, allow for the radio to temperature stabilize for at least 30 minutes before calibrating the frequency. Also refrain from frequency calibrating the radio in extreme high, low or fluctuating ambient temperatures as this will introduce error into the calibration process. Please refer to the [SmartSDR for Windows Software User's Guide](#) for detailed frequency calibration instructions.

16 KEY CONTACTS

16.1 HEADQUARTERS / USA

FlexRadio Systems - U.S.A

4616 W. Howard Lane

Suite 1-150

Austin, TX 78728

U.S.A.

Phone: +1 512-535-4713

Fax: +1 512-233-5143

Email: info@flexradio.com

Support: <https://helpdesk.flexradio.com>

Community: <https://community.flexradio.com>

16.2 EUROPE

FlexRadio Systems Representative for EU

SDR-Funktechnik GmbH

Godeke-Michels-Weg 12

D-21762 Otterndorf

Germany

Phone: (+49) 4751 900501

Fax: (+49) 4751 998569

Email: FlexRadio-EU@t-online.de

www.flexradio.com

17 REGULATORY REQUIREMENTS

17.1 EUROPEAN CONFORMITY (CE)

"CE" marked devices meet the essential requirements of Directive 1999/5/EC



The exclamation point warning symbol means that the system is to be operated in a non-harmonized frequency band and/or according to the laws of the telecommunications authority in the country of use.

Please ensure that you have acquired the device for the use land approved operation, and that the respective national frequency allocations are respected. See also the warnings contained in this guide.

Waste Disposal

The device may not be disposed of with household waste! This device complies with EU Directive on Electronic and electrical equipment (WEEE regulation) and will therefore not be disposed of with household waste. Dispose of the device at your local collection points for electronic equipment!





European Union Declaration of Conformity

FLEX-6000 Amateur Radio Transceiver Series (FLEX-6300 /FLEX-6500 / FLEX-6700 / FLEX-6700R)

According to Radio and Telecommunications Terminal Equipment Directive, (R&TTE) 1999/5/EC - using the Standards:

EN 301 489-1 v1.8.1 (2008-04)

EN 301 489-15 v1.2.1 (2002-08)

EN 301 783-1 v1.2.1 (2009-07)

EN 301 783-2 v1.2.1 (2010-07)

EN 60950-1 : (2011)

Type of Equipment: Base Station
Equipment Class: B

WE THE UNDERSIGNED HEREBY DECLARE THAT THE EQUIPMENT SPECIFIED ABOVE CONFORM TO THE ABOVE STANDARDS.

FlexRadio Systems Date of Testing: April 24, 2013

FlexRadio Systems,
4616 W. Howard Lane,
Suite 1-150
Austin, Texas 78728 U.S.A.

Person Responsible: Gerald Youngblood (Signature on file)